



TGS 4x2 Chassis



Engines

MAN 6-cylinder 4-valve in-line engine, with Common Rail injection, turbo-charging and intercooling, EDC engine regulation, emission standard EURO4, with OBD (on-board diagnosis) and NOX-control, external controlled exhaust gas recirculation (EGR) and PM-KAT. No AdBlue fuel additive necessary. Fitted with MAN Engine Valve Brake (EVB).

Transmission

MAN 12 speed TipMatic (ZF AStronic) gearbox. 12 forward speeds, 2 reverse ratios. Suitable for gross train weights up to 65T (occasionally up to 90T+GTW upon application). Automated constant-mesh gearbox. With MAN TipMatic, shifting and clutching are electro-pneumatic - there is no clutch pedal. Normal mode is automated with manual mode available (shifting via fingertip lever). Driving with engaged PTO only in gears 1, 3 or 5. 'M' setting for precise low-speed manoeuvring in forward and reverse.

Intake / Exhaust System

Raised air intake mounted on the rear L/H side of the cabin with air filter housing mounted under rear of cabin. Exhaust is downswept - position varies with fuel tank installation options. Optional upright exhaust available.

Wheels and Tyres

Fitted with 295/80 R22.5 tyres on 8.25 x 22.5 10 hole steel disc wheels.

Spare wheel supplied loose and mounted temporarily on frame. Basic wheel changing equipment fitted in cabin storage lockers.

Front Axle / Front Suspension

MAN dropped front axle with 'sealed for life' hub units. Parabolic springs with shock absorbers and stabiliser. 7,100kg capacity on prime movers. 8,000kg capacity on rigid chassis.

Rear Axle / Rear Suspension

MAN Hypoid axle with "sealed for life" hub units. 8 air bag electronically controlled air suspension (ECAS) with stabilisers and shock absorbers. Fitted with Differential Locks and Interaxle lock. Optional differential ratios available: 2.85, 3.36, 3.70, 4.11, 4.63. Multi leaf springs and MAN hub reduction axles available on some models. Suspension design rating: 13,000kgs.

Fuel Tanks

Aluminium fuel tanks fitted with lockable fuel caps. 400Ltrs standard fitted to primemovers or optional 600Ltrs, 780Ltrs or 780/250Ltrs combination. 400Ltrs standard fitted to rigid wheelbases or optional 600Ltrs, 800Ltrs or 600/400Ltrs combination.

Engine	Model	Rating	Torque
480 Hp	MAN D26 12.419 Ltrs	480 hp/353kW @ 1500 - 1900rpm	2300Nm @ 1000 - 1400 rpm
440 Hp	MAN D20 10.518 Ltrs	440 hp/324kW @ 1500 - 1900rpm	2100Nm @ 1000 - 1400 rpm
400 Hp	MAN D20 10.518 Ltrs	400 hp/294kW @ 1500 - 1900rpm	1900Nm @ 1000 - 1400 rpm
360 Hp	MAN D20 10.518 Ltrs	360 hp/265kW @ 1500 - 1900rpm	1800Nm @ 1000 - 1400 rpm
320 Hp	MAN D20 10.518 Ltrs	320 hp/235kW @ 1500 - 1900rpm	1600Nm @ 1000 - 1400 rpm

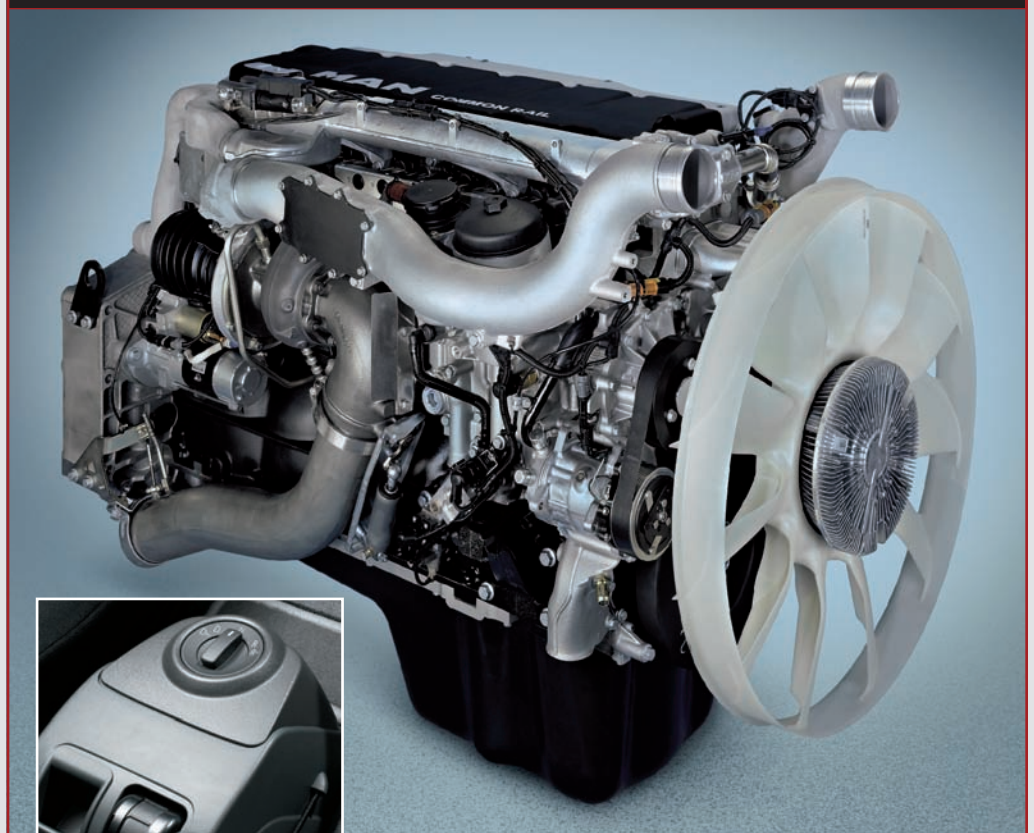

Engine	Model	Transmission Ratios	Std. Differential Ratios
480 Hp	ZF 12 AS 2330 DD	15.86 - 1.00	3.08
440 Hp	ZF 12 AS 2130 DD	15.86 - 1.00	3.08
400 Hp	ZF 12 AS 2130 DD	15.86 - 1.00	3.08
360 Hp	ZF 12 AS 2130 DD	15.86 - 1.00	3.08
320 Hp	ZF 12 AS 2130 DD	15.86 - 1.00	3.08

Frame

Ladder frame made from QstE500TM high strength steel. Frame Dimensions 270mm x 85mm x 8mm. Chassis fitted with ECE compliant Front Underrun Protection System (FUPS). Steel bumper available on some models.

Brake System

MAN Electronic Brake System (EBS) with ABS standard. Disc Brakes fitted to all axles with brake wear monitoring and wear equalisation function. Full air operated system fitted with air dryer. MAN 'easy start' function holds service brakes on hills for smoother pulling away. Anti jack-knife brake.

Clutch

Single plate 430mm diameter clutch - asbestos free.

Speed Limiter

Vehicle electronically limited to 100kmh.

Cab Options

M Cab (day) 2240mm wide, 1880mm long.

L Cab (single sleeper) 2240mm wide, 2280mm long.

LX Cab (single sleeper high roof) 2240mm wide, 2280mm long.

Cab Exterior

Cab compliant with ECE R29 safety requirements. All metal parts are Galvanised. 65 degree cab tilt angle, 87 degree door opening. Exterior sunvisor. Entry lighting for driver and passenger. Central locking for both doors. Electrically adjustable and heated mirrors including kerb mirrors. Lockable front access panel. Built-in side storage lockers on L and LX cabins. Electrically operated cab tilting mechanism. Mechanical roof hatch. Air sprung cab mounts front and rear (coil sprung on M cab). Chrome trim to front grille. Stone guard grille in front of radiator. Cab door extensions (excl steel bumper models). Full aerodynamic kit and roof spoiler options available for most models.

Cab Interior

High comfort drivers seat with air suspension, integrated seat belt and arm rests. Factory fitted climate control system. Double DIN size radio/CD player with MAN 6 speaker sound system with sub-woofer (no sub-woofer in M cab). Electrically operated power windows, interior sunblinds to windscreen and both doors. Full curtains to sleeper cabs. Slide-out central storage box between seats. Large storage drawer in dash console, modular cup holder, storage compartment in door armrest. Silver dashboard trim strip, glasses compartment in dashboard. Reading lamps for driver and co-driver. Storage lockers above windscreen in LX cab.

Instrument Panel

Full electronic Base Line dash display with easy access to vehicle information systems. Permanent gauges: tachometer, speedometer, odometer, air pressure gauges, water temperature, fuel guage, indicator operation, gear selection. Sample electronic display: time, outside temperature, turbo boost, trip meter, brake wear, oil level, fuel consumption, battery voltage, etc. Warning lights for all major functions such as: diff lock status, low air pressure, low fuel, lights, cab lock, air suspension, etc.

Steering

Fully adjustable steering wheel with pneumatic lock. Multifunction steering wheel interfaces with CD/radio, cruise control and electronic dash display functions.

Electrical System

24V Electrical system with manual battery isolation switch. 80 Amp alternator, 2 x 175Ah batteries.

Lights

Headlights fitted with longlife H7 type globes, additional integrated lower spotlight/foglight with longlife H7 globes. LED strip parking light. Lighting system operation check. Cornering light which automatically illuminates when indicator is activated and lights are switched on below 30kmh - concealed in front foglamp cluster. (Cornering light not available with steel bumper).

Paintwork

Cab, bumper and lower plastics finished in Traffic White (RAL9016). Chassis finished in Graphite Black (RAL 9011). Where steel bumper is fitted, the bumper and lower plastics are finished in grey and door extensions are not fitted.



Specification Data

GVM Max: 18,000kg

Weights kg:	Wheelbase (mm)	Front	Rear	Total
M Cab	3600	4775	1970	6745
	5100	4750	2370	7120
L Cab	3600	4930	1970	6900
	5100	4905	2370	7275
LX Cab	3600	4950	1970	6920
	5100	4925	2370	7295

Turning Circle:	Wheelbase (mm)	Kerb to Kerb (m)	Wall to Wall (m)
	3600	13.2	14.9
	5100	18.0	19.6

Chassis Dimensions:	Wheelbase (mm)	FOH	ROH	OAL	CA	CF	AE	BL	H1	H2	H3	H4	W1	W2
M Cab	3600mm	1475	800	5875	-	-	-	-	3073	2998	953	923	2490	2240
	5100mm	1475	2900	9475	4530	7430	570	7590	3086	3004	968	938	2490	2240
L Cab	3600mm	1475	800	5875	-	-	-	-	3073	2998	953	923	2490	2240
	5100mm	1475	2900	9475	4215	7115	885	7275	3086	3004	968	938	2490	2240
LX Cab	3600mm	1475	800	5875	-	-	-	-	3371	3296	953	923	2490	2240
	5100mm	1475	2900	9475	4215	7115	885	7275	3384	3302	968	938	2490	2240

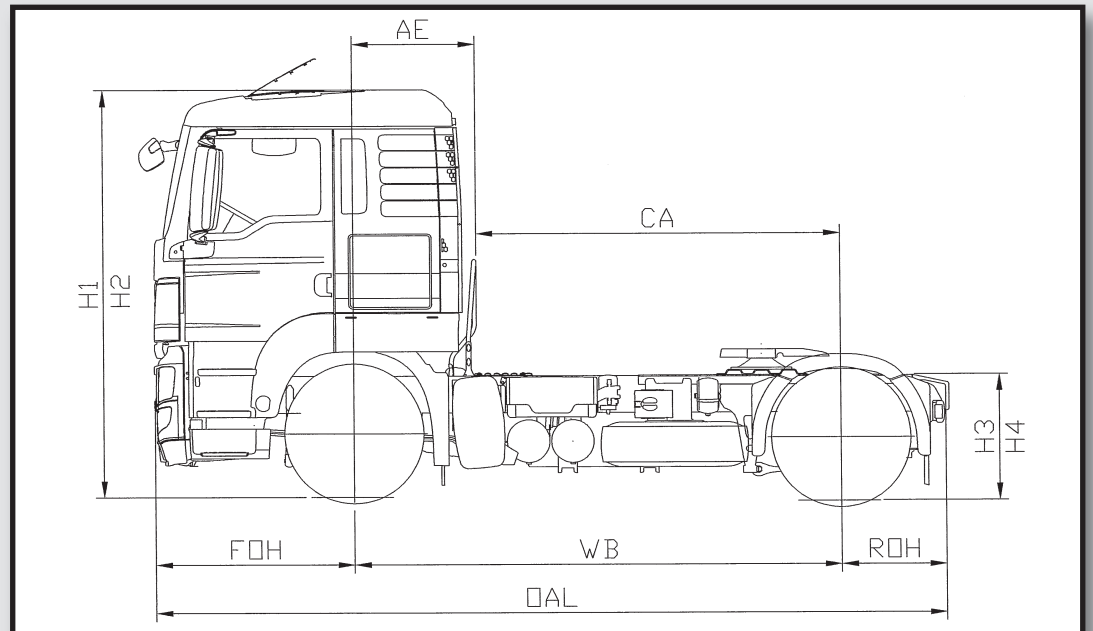
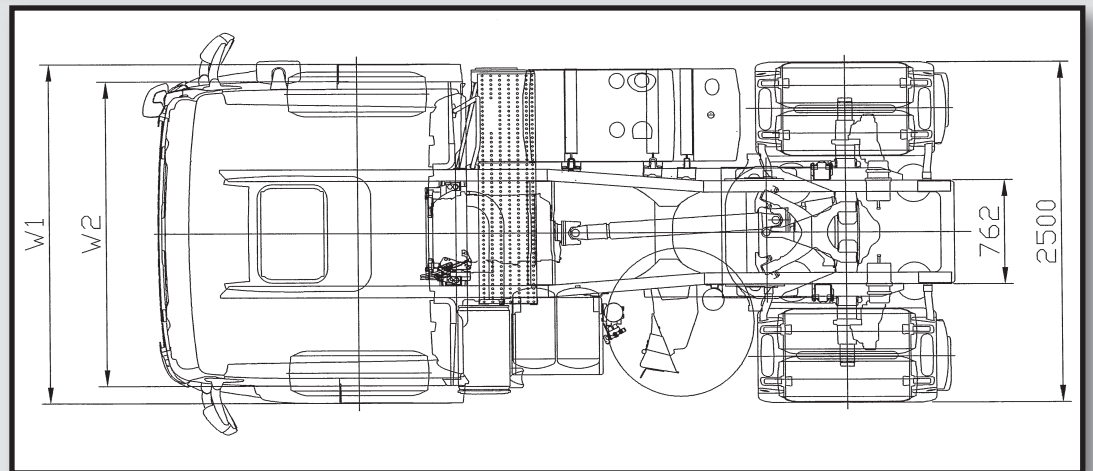
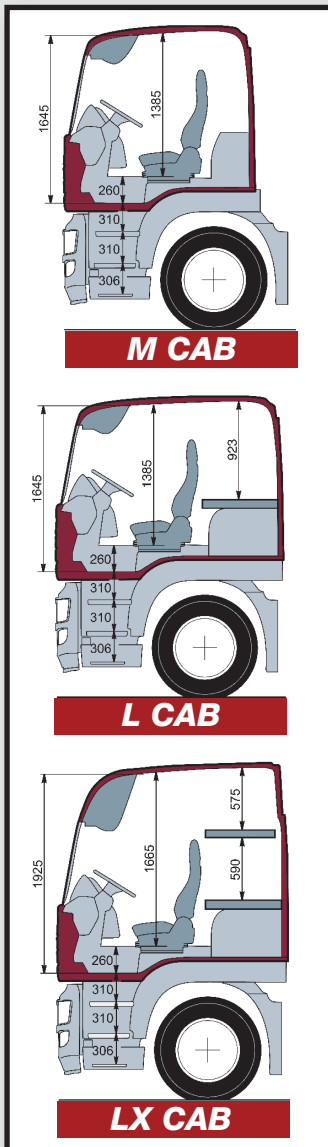

1. All above dimensions are subject to proper weight distribution.
2. State and Federal regulations over ride information supplied on this brochure.
3. Vehicle depicted in this specification sheet is for illustration purposes only.
4. Maximum BL (ROH) is calculated using 60% of WB or 3.7mt whichever is less (ensure sufficient chassis rail is available to comply with State regulations).
5. Tare weight includes 400 litres of fuel, 75kg driver, spare wheel and steel wheels.
6. Specifications are subject to change without notice. Copyright © 2009, MAN Automotive Imports Pty Ltd.



MAN Automotive Imports Pty Ltd

72 Formation Street, Wacol, Qld 4076 • PO Box 301, Goodna Qld 4300

Telephone: 07 3271 7777 • Facsimile: 07 3271 2720 • www.man.com.au